

***Guideline for assessing the visual quality  
for systems in multiple-sheet insulating glass***

# Guideline for assessing the visual quality for systems in multiple-sheet insulating glass

---

## Contents

<b>1.0 Scope of application</b> . . . . .	2
<b>2.0 Test principles</b> . . . . .	2
<b>3.0 Permissibilities for slat systems</b> . . .	4
<b>4.0 Roller-blind systems and plissé systems</b> . . . . .	9
<b>5.0 General notes</b> . . . . .	12
<b>6.0 Special notes</b> . . . . .	12

## 1.0 Scope of application

1.1 This guideline applies to the assessment of the visual quality of flexible and rigid systems installed in the cavity, such as slats, films, light-directing sections, plissé etc. with all the visible parts. The multiple-sheet insulating glass is assessed in accordance with the relevant guidelines and standards.

1.2 The visual quality of the installed systems is assessed in accordance with the following test principles and test criteria such as viewing angle, viewing surfaces, permissibilities and special features of the individual systems. The remaining room-side visible surface of the integrated systems in the installed state is assessed.

1.3 Further guidelines and standards

- DIN 18073 “Roller blinds and solar control and blackout systems in buildings”
- EN 13120 “Internal blinds – Performance requirements including safety”  
Guideline for assessing the visual quality for systems in multiple-sheet insulating glass

## 2.0 Test principles

### Preliminary remarks

- Noises which are generated by the opening or tilting of windows and by travel movements are due to technical particularities and do not constitute a defect.
- Assessment criteria apply only to horizontally and vertically aligned systems.
- The distance between slat and spacer is not a visual criterion.
- Signs of wear are not the subject of visual quality.

### 2.1 Slat systems

Crucial to the testing of slat systems are the visible surfaces of the slats, the head profile and the foot or end profile, and the position of the slats in the top and bottom end positions (not partial surfaces, like hangings moved halfway down). In the case of systems retained at the sides (e.g. with tension cords) the slat profiles are assessed with regard to the surface and the side retainers.

### 2.2 Film systems - plissé systems

In the case of film and plissé systems, the surfaces and their appearance must be assessed with regard to bulges and creases in the top and bottom end positions, in addition to the individual parts.

### 2.3 Test criteria

2.3.1 It is generally necessary to proceed from a viewing angle which corresponds to standard room utilization from the inside according to Table 1 below. Viewing from the outside is always conducted at a distance of more than 2.0 m. The objections must not be marked and no direct sunlight or artificial light is permitted to shine on the slats or film. Testing is conducted under conditions of diffuse daylight (such as overcast sky) without direct sunlight or artificial light. The glazing inside rooms (interior glazing) should be tested under normal (diffuse) illumination intended for room utilization at a viewing angle preferably per-

pendicular to the surface. The test preconditions apply to the top and bottom end positions. A system that is only partially closed cannot be assessed, since there is no function here as called for by the requirements of solar control, privacy screening and anti-glare protection.

2.3.2 Test conditions and viewing distances from specifications in product standards for the viewed glazing may differ from these and are not taken into consideration in this guideline. The test conditions described in these product standards often cannot be maintained at the actual building.

Product	Viewing angle	Distance to the viewing surface
Shutter system	90°	1.5 m
Film system *	90°	2.0 m
Light-directing system*	90°	2.0 m
Slat system tensioned at the sides	90°	1.5 m

\*Table applies only to systems with diffuse reflection

(Table 1)

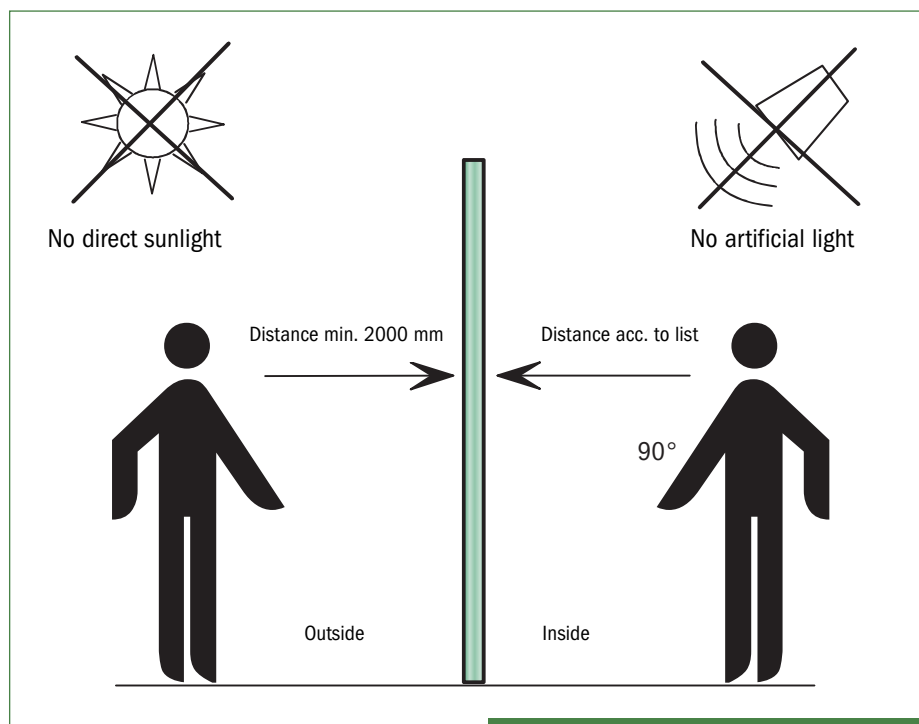

# Guideline for assessing the visual quality for systems in multiple-sheet insulating glass

## 2.4 Viewing surfaces

The surface to be assessed is divided into

- Edge zone = 10 % of the edge surface from the respective width and height dimensions (less strict assessment)
- Main zone = visible surface remaining from the centre of the surface to the edge zone (strict assessment)

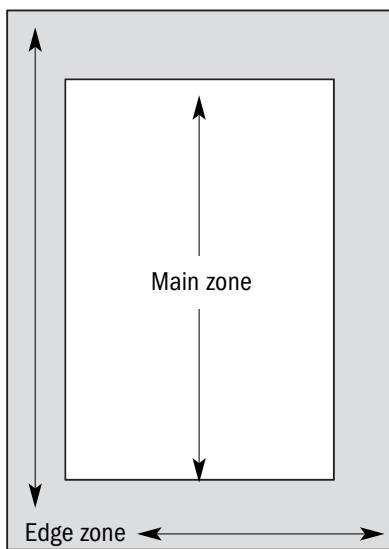

## 3.0 Permissibilities for slat systems

### 3.1 Identifiable surface deviations

3.1.1 Abrasion caused by technical factors in the area of the guide rails, tension cords, lift cords and bands etc. due to the movement of the slats when turning and

during upward and downward movement cannot be ruled out. These residues or discolorations are assessed in accordance with Tables 2, 3, 4 and 5.



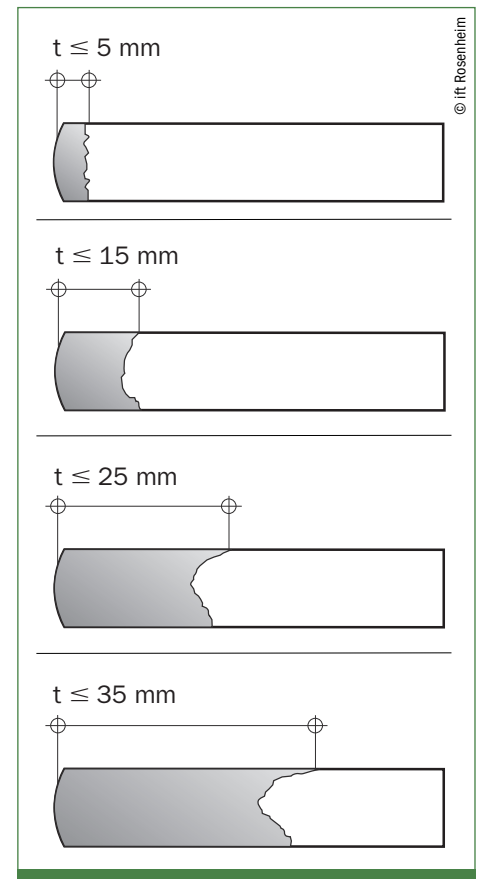

Assessment criterion	Assessment
Discolouration of the slat ends by abrasion	acc. to Table 5
Traces of abrasion in the cavity	partly permissible acc. to Table 5
Residues: e.g. butyl on the slats	partly permissible acc. to Table 5

(Table 2)

Example



(Table 3)

Colour of slat	Contrast
Colour of contamination	
	0 - 20 %
	20 - 40 %
	40 - 60 %
	60 - 80 %
	80 - 100 %

© ift Rosenheim

(Table 4)

3.1.2 Spots, inclusions, specks, coating defects etc. are assessed as follows:

Permissible per m<sup>2</sup> area

Edge zone: max. 4 pcs. dia. ≤ 3 mm

Main zone: max. 2 pcs. dia. ≤ 2 mm

3.1.3 Scratches in the main and edge zones Hairline scratches barely visible, not allowed in large numbers if the sum total of their individual lengths is not more than 30 mm.

The maximum individual length of scratches is 15 mm.

Depth of discolouration	Contrast				
	0 - 20 %	20 - 40 %	40 - 60 %	60 - 80 %	100 %
t ≤ 5 mm	OK	OK	OK	OK	OK
t ≤ 15 mm	OK	OK	OK	OK	no
t ≤ 25 mm	OK	OK	OK	no	no
t ≤ 35 mm	OK	OK	no	no	no
> 35 mm	no	no	no	no	no

© ift Rosenheim

(Table 5)

# Guideline for assessing the visual quality for systems in multiple-sheet insulating glass

## 3.2 Permissible slat offset

- The slat offset of the two maximum offset slats of a sheet is assessed.
- The slat offset is only assessed for one-piece hangings; split hangings (two hangings in one sheet) are not covered by this guideline.

Sheet width		Maximum slat offset
from	to	
0	1000	6
1001	2000	8
2001		10

Dimensions in mm

(Table 6)

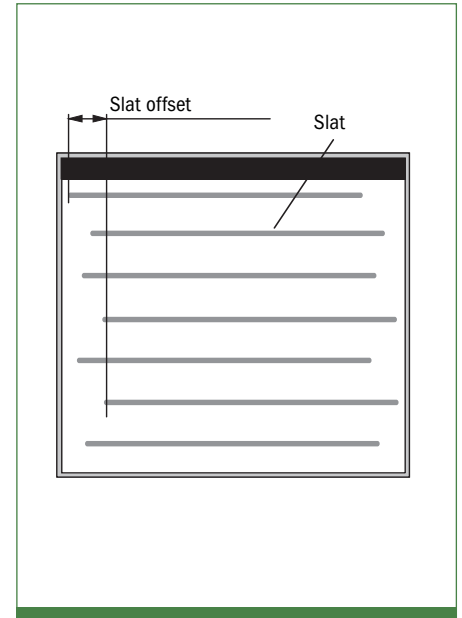

## 3.3 Deviation from the perpendicular/skew

The maximum permissible deviation  $A$  from the perpendicular in the top and bottom end positions is 6 mm per metre of slat length  $L$ , but max. 15 mm.

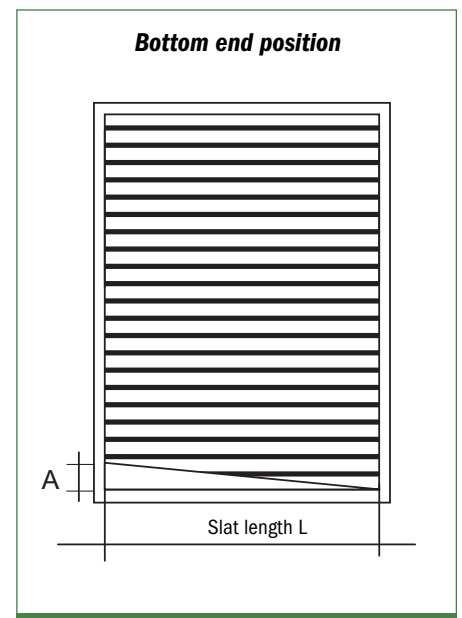
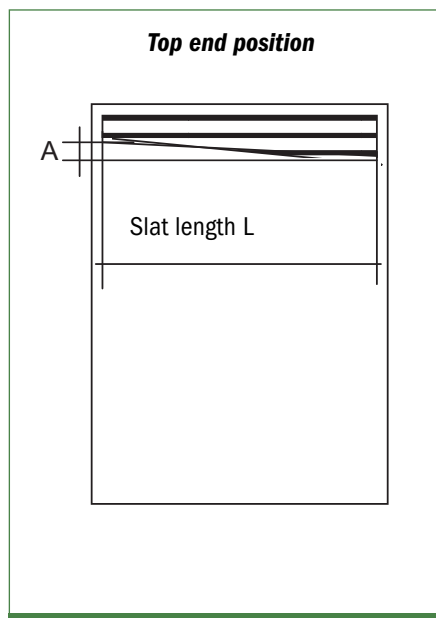

**3.4 Permissible deviation from shape**

3.4.1 Permissible contortion/distortion

**Contortion/distortion (EN 13120):**

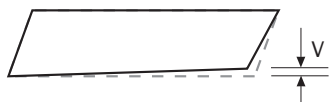

Angular deviation V between one end of the slat and the other end

2 mm/m

Local distortion

Permissible in the area of the press cut

(Table 7)

3.4.2 Permissible deflection

The deflection of slats is assessed in the closed hanging position.

**Deflection D (EN 13120):**



End rod: 4 mm

Slat (measured in the closed hanging position)

Length of slats in m	Maximum values of deflection of slats in mm
$L \leq 1,5$	5
$1,5 < L \leq 2,5$	10
$2,5 < L \leq 3,5$	15
$L > 3,5$	20

**Longitudinal curvature of slat C (EN 13120):**



L = length of slat

$$C = \frac{1}{2} L^2$$

(Table 8)

# Guideline for assessing the visual quality for systems in multiple-sheet insulating glass

## 3.5 Permissible deviation with incomplete turning of slats

2 % of the total number of slats.

The slats are permitted to catch during their downward travel in such a way that they flip into the intended position only when the slats are turned. The slats are not permitted to catch permanently.

## 3.6 Minimum closing angle

The closing angle of slat systems must correspond to the system description. The minimum closing angle should be  $45^\circ$ , unless specified otherwise.

## 3.7 Irregular filtering through of light

Irregular light penetration between the slats is permissible,

- provided this can be attributed to the pre-specified tolerances of the individual components,
- the remaining tolerances of the shutters are maintained

Irregular filtering through of light can occur partly due to:

- irregular deflection of individual slats
- closing angle tolerances

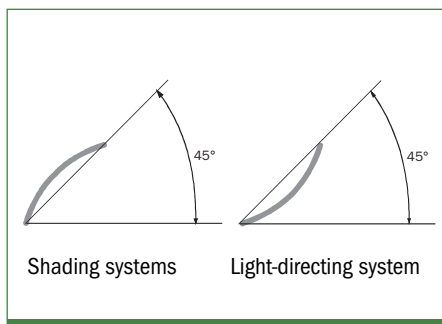

## 3.8 Closing angle tolerances at the surface

The following is assessed:

- the average value of 3 consecutive slats
- at the hanging heights 90 %, 50 % (centre), 10 %

The maximum angular deviation with regard to the hanging centre is permitted to be:

Systems	up to a height of	above to a height of	Tolerance
Shading systems	1000 mm		$\pm 8^\circ$
		1001 mm	$\pm 12^\circ$
Light-directing systems	1000 mm		$\pm 10^\circ$
		1001 mm	$\pm 12^\circ$

(Table 9)

## 3.9 Accuracy of the opening angle of slat systems which open only on one side

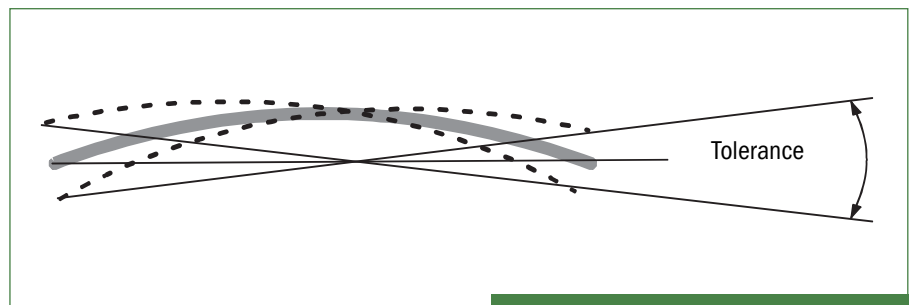

After maximum opening of the slat system, the slats in the middle height third of a vertical sheet are permitted to deviate from the horizontal in accordance with the following table:

Sheet height in mm		Tolerance
from	to	
	1000	$\pm 7^\circ$
1001	2000	$\pm 8^\circ$
2001	3000	$\pm 9^\circ$
3000		$\pm 10^\circ$

(Table 10)



### 3.10 Swivel capability of slat systems closing on both sides with central mounting

The swivel capability of the slats complies with DIN 18 073 and must be at least 90° about the longitudinal axis.

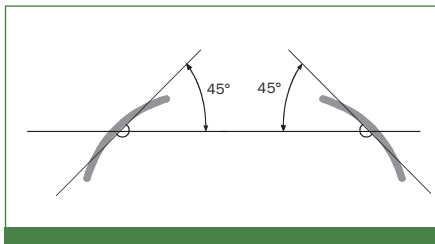

### 3.11 Swivel capability of slat systems closing on one side with central mounting

The swivel capability of the slat is only assessed on the closing side and must be at least 45° about the longitudinal axis.

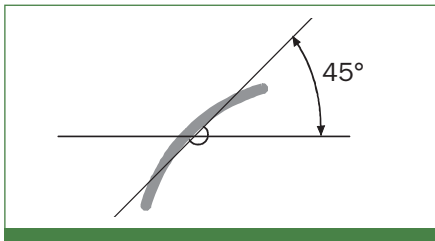

### 3.12 Overlap of the slats

The individual slats must overlap at the maximum closing angle by at least 1 mm.

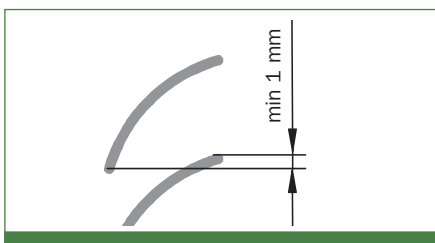

### 3.13 Slat closure

With the hanging closed and with a horizontal angle of view (90° to the hanging), no direct light penetration should be possible.

## 4.0 Roller-blind systems and plissé systems

### 4.1 Identifiable surface defects

(the hanging surface to be assessed follows Point 2.3)

#### Edge zone: 1. Inclusions, bubbles, spots, specks, stamping defects, residues, coating defects, etc.

Sheet surface  $\leq 1 \text{ m}^2$ , max. 4 pcs. each  $\leq 3 \text{ mm}$

Sheet surface  $\geq 1 \text{ m}^2$ , max. 4 pcs. /  $\text{m}^2$  each  $\leq 3 \text{ mm}$

#### 2. Scratches

Sum total of individual lengths max. 90 mm

Individual length max. 30 mm

#### Main zone: 1. Inclusions, bubbles, spots, specks, stamping defects, residues, coating defects, etc.

Sheet surface  $< 1 \text{ m}^2$ , max. 2 pcs. each 2 mm

Sheet surface  $> 1 \text{ m}^2$ , max. 3 pcs. each 2 mm

Sheet surface  $> 2 \text{ m}^2$ , max. 5 pcs. each 2 mm

#### 2. Scratches

Sum total of individual lengths max. 45 mm

Individual length max. 15 mm, not in large numbers.

### 4.2 Deviation from the perpendicular

The deviations from the perpendicular are assessed in the following positions

- top end position (roller blind / plissé opened)
- bottom end position (roller blind / plissé closed)

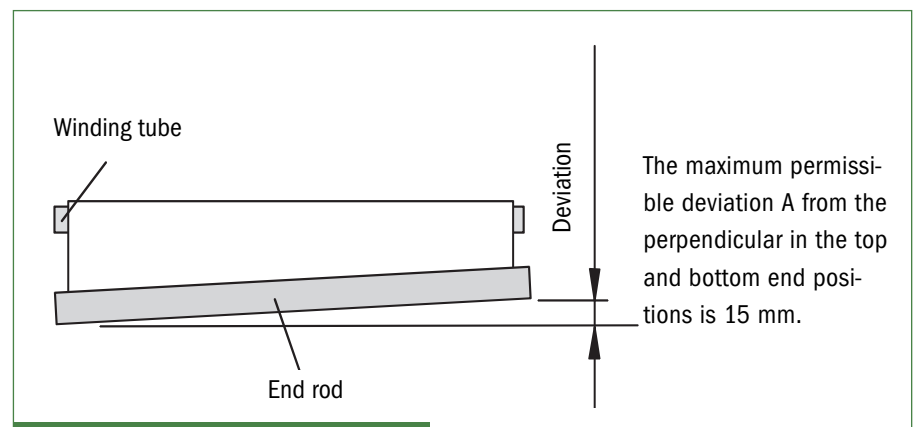

# Guideline for assessing the visual quality for systems in multiple-sheet insulating glass

## 4.3 Bulge and crease formation

Bulges and creases do not constitute a defect, provided they do not impair the function of the system.

## 4.4 Filtering through of light

- Direct filtering through of light (light penetration, without obstruction by the hanging, etc.) is not permitted.
- Indirect filtering through of light (e.g. via reflections) is permitted.

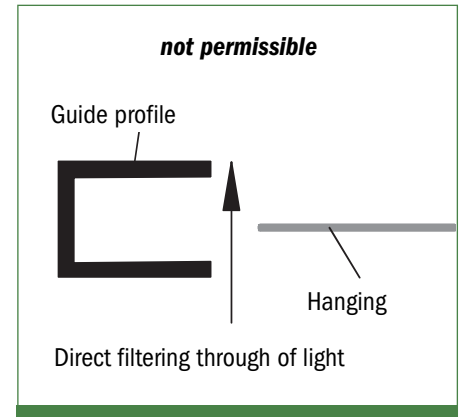
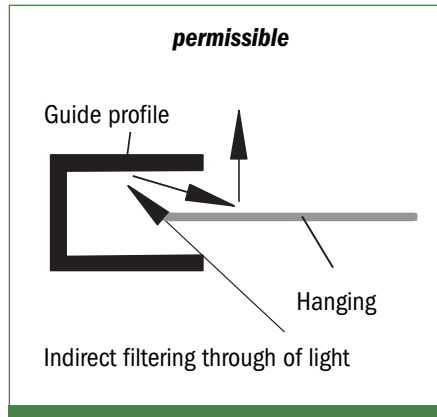

## 4.5 Curling of free hanging edges

A cut edge which is not fastened to any other component (end rod, winding tube, etc.) is termed a free hanging edge.

Curling of free hanging edges is permitted if

- there is no direct filtering through of light at a perpendicular viewing angle
- this does not disrupt the function of the roller blind

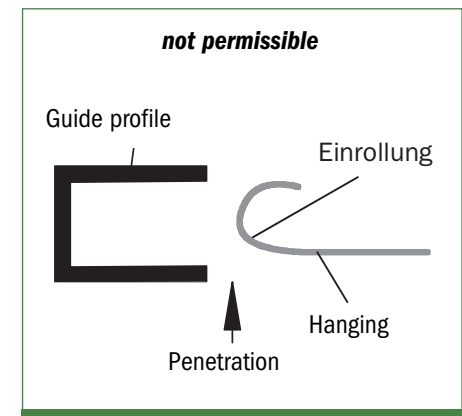
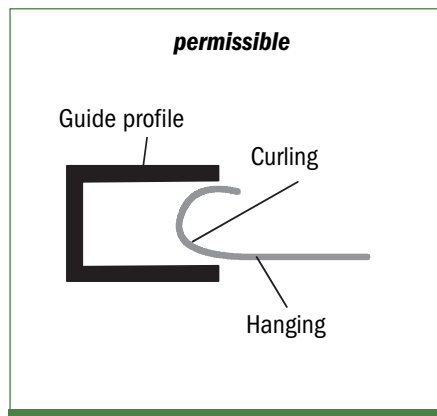
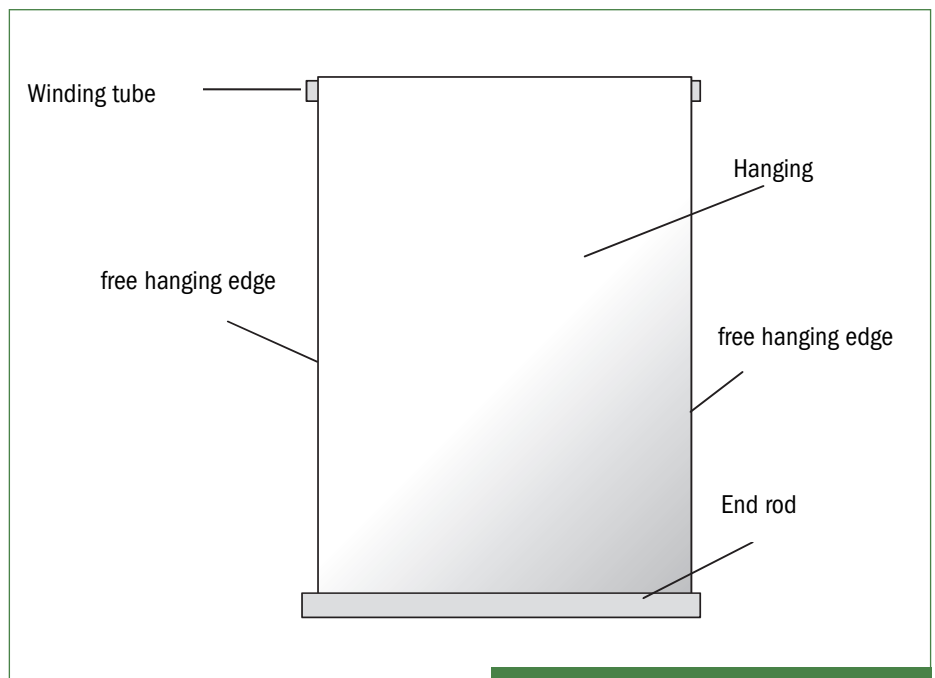

#### 4.6 Hanging variation in the guide area

Hanging changes, e.g. due to abrasion in the area of guides, are permissible if the penetration changes by no more than 20 %.

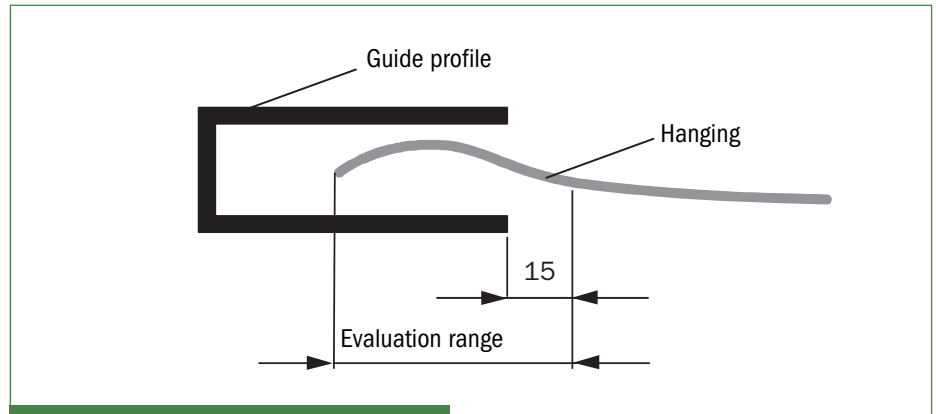

#### 4.7 Plissé systems

The dead weight of the fabric causes the course of the fold width to change between the first and last folds. This phenomenon is more noticeable on hangings with heights of more than 1 m than on smaller hangings. The difference in the course is not cause for complaint in that it stems from the properties of the fabric. The first folds, also due to the effect of heat, naturally tend to flatten slightly, which means however that the fold is maintained. The fabric must ensure that the folds come together neatly in each lifting operation.

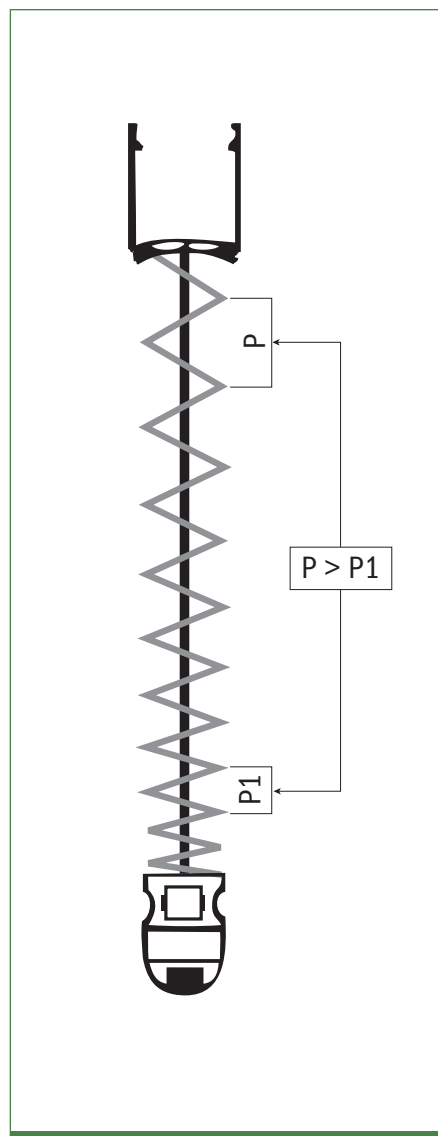

## 5.0 General notes

This guideline is an evaluation yardstick for assessing the visual quality of slat, roller blind and plissé systems in the multiple-sheet insulating glass. The assessment should always be based on the assumption that, as well as the visual quality, the features of the product essential to performing its functions are also taken into consideration.

A synchronization of several elements cannot be guaranteed.

## 6.0 Special notes

6.1. In all the systems, a visible gap can arise for technical reasons on the left and/or right of the head profile. Effects arising from temperature-induced linear deformations can never be ruled out completely and are not cause for complaint.

6.2. The individual slats are held in place by so-called ladder cords. These ladder cords can change their position depending on the specific system. These ladder cords are not regularly unfolded.

6.3. In all systems, covers can be placed onto the glass surfaces. These covers can for example consist of enamel or films on glass. They are not the subject matter of any evaluation by this guideline, and must be considered separately.

**This bulletin was produced by:** Working group 'Systems inside the cavity' at Bundesverband Flachglas e.V. · Mülheimer Straße 1 · D-53840 Troisdorf

**With the assistance of:** ift Rosenheim

© **Bundesverband Flachglas e. V.** Approval for reprinting will gladly be given on request. However, reprinting or reproducing the document or parts thereof is not permitted without our express approval. No claims can be derived from the publication.



Bundesverband Flachglas e.V.  
Mülheimer Straße 1  
53840 Troisdorf